

S9033RT/S9043RT/S9053RT

LARGE DECK, ROUGH TERRAIN SCISSOR LIFTS



- Large deck rough terrain scissor lifts
- Excellent rough terrain performance
- Easy to operate
- Heavy duty design
- Ideal for construction applications

 **snorkel**[™]
www.snorkellifts.com

LARGE DECK, ROUGH TERRAIN SCISSOR LIFTS

S9033RT/ S9043RT/S9053RT

DIMENSIONS	S9033RT*	S9043RT*	S9053RT*
Max. working height	11.8m	15.1m	17.9m
Max. platform height (A)	9.8m	13.1m	15.9m
Platform size (stowed)	3.95m x 2.28m		
Platform size (single deck extended)	5.33m x 2.28m		
Platform size (optional dual deck extended)	6.65m x 2.28m		
Extension deck length	1.44m	1.44m	1.44m
Overall width (B)	2.28m	2.28m	2.28m
Overall length without stabilizers (D)	4.08m	4.08m	4.08m
Overall length with stabilizers	4.77m	4.77m	4.77m
Stowed height (C)	2.97m	2.99m	3.2m
Min. height (guardrails folded)	1.98m	2.18m	2.33m
Ground clearance	274mm	274mm	274mm

PERFORMANCE	S9033RT*	S9043RT*	S9053RT*
Platform capacity (SWL)	1,135kg	681kg	681kg
Max. drive height	9.8m	13.1m	13.1m
Max. wind speed	12.5m/s	12.5m/s	12.5m/s
Max. drive speed (stowed)	6.7km/h	6.7km/h	6.7km/h
Max. drive speed (elevated)	0.8km/h	0.8km/h	0.8km/h
Raise/lower time	45/30 sec	50/40 sec	55/50 sec
Gradeability	50%	50%	40%
Max. stabilizer levelling, front to rear	7°	7°	7°
Max. stabilizer levelling, side to side	12°	12°	12°
Inside turning radius	2.03m	2.03m	2.03m
Outside turning radius	5.28m	5.28m	5.28m
Tires	12 x 33 foam filled		
Controls	proportional joystick		
Drive system	4-wheel drive		

POWER	S9033RT*	S9043RT*	S9053RT*
Power source	Kubota diesel		

WEIGHT	S9033RT*	S9043RT*	S9053RT*
Weight without stabilizers	6,759kg	7,500kg	7,484kg
Weight with stabilizers	7,401kg	8,147kg	8,829kg

TURNING RADIUS

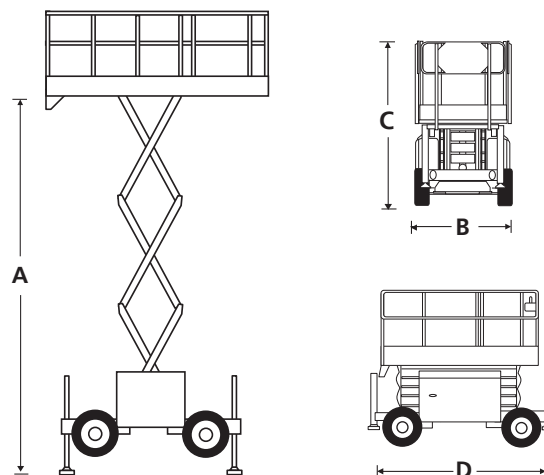
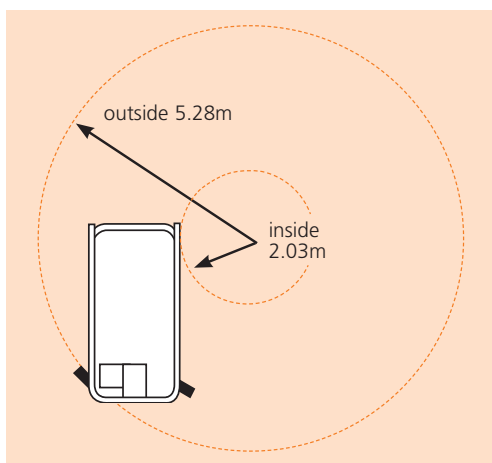

STANDARD FEATURES

- 4-wheel drive
- 4 hydraulic outriggers with automatic levelling (S9053RT only)
- Single powered deck extension
- Proportional controls
- Foam filled tires
- Power line to platform
- Platform overload system
- Drive motion alarm
- Descent alarm
- Locking oscillating axle
- Manual lowering valve
- Flashing amber light (x2)
- Fold-down guardrails
- Dual lanyard attachment points
- Hour meter & on-board diagnostics display
- 2 year parts & labor, 5 year structural warranty
- ANSI compliant

OPTIONS

- Special paint colors
- Nylon spreader pads (set of 4)
- Environmental hydraulic oil
- Cold weather package (block heater + battery warm up)
- Dual manual extension decks
- Dual powered extension decks
- Hydraulic generator 110V 2kW
- 12kW generator package
- 4 hydraulic outriggers with automatic levelling (S9033RT + S9043RT only)
- Non-marking foam filled tires
- Snorkel OnSite™ telematics

snorkel www.snorkellifts.com

P.O. Box 1160
St. Joseph, MO 64502-1160, USA
Tel: 1 (785) 989-3000
Toll-free: 1 (800) 255-0317
Fax: 1 (785) 989-3070

Email: sales.usa@snorkellifts.com